

9 Mowidec-TT

9.3 Service instruction



Service instruction

Presentation

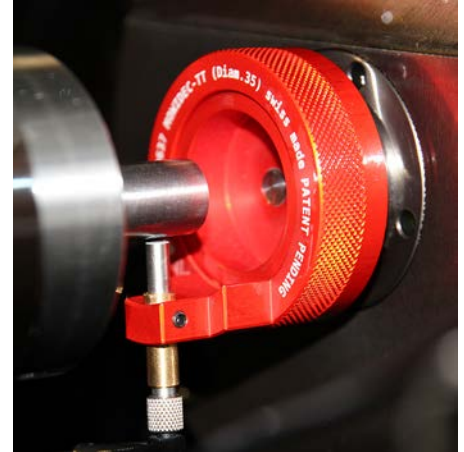
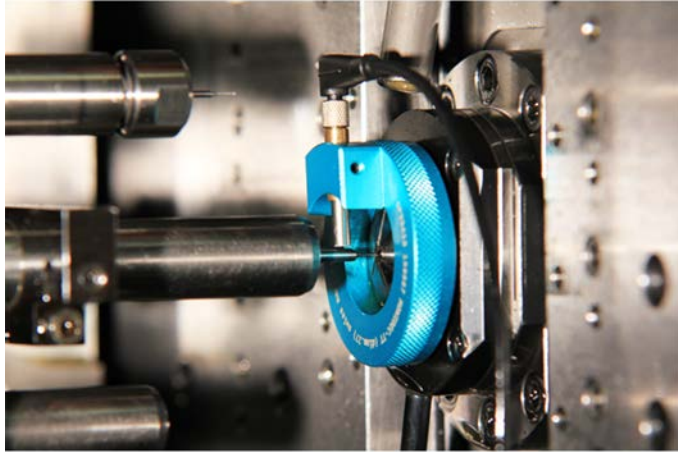

The Mowidec-TT spindle centring system was developed by Wibemo SA, in collaboration with a turning workshop and the Haute Ecole Arc of St-Imier (Switzerland).

An international patent is filed and protects this development in all possible variants of use using the same principle.

It is intended primarily for automatic turning lathes and various machines to align the pins and cylindrical rotating or fixed tools.

With Mowidec-TT, centring the tools on the drilling or counter-boring spindles becomes very easy and especially very fast. With this user friendly system and reliable components, the life of your tools and the quality of your work will be greatly improved.

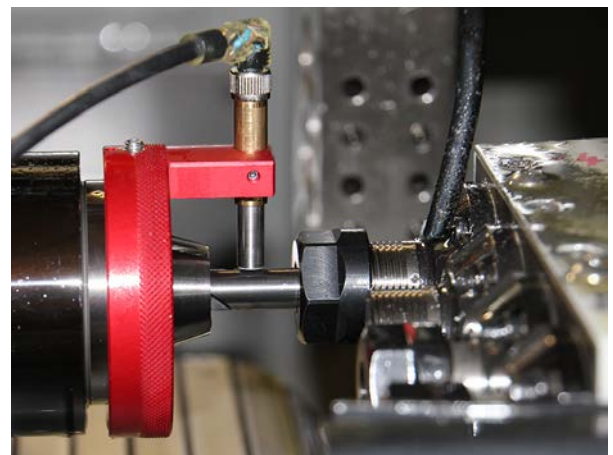
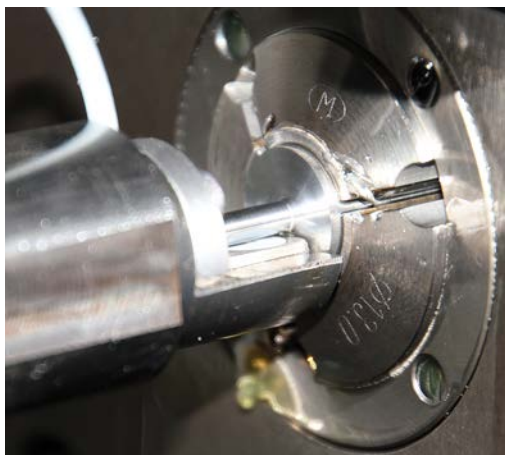

Service instruction

Advantages of the system

Advantages of the system

New MOWIDEC-TT mobile works on **rechargeable batteries**

Simple and quick use

No disassembly of the barrel or clamp

Significant **saving of time** during the adjusting and starting work

Centering directly on the tool in working position **without contact**

Easier and more accurate error reading than with the dial gauge (mirror) or centring steady rest

No calibration required

High measurement **resolution** to the nearest **micron**

Various detectors and monitoring supports available

Ergonomic design with the LCD screen offers **clear and accurate reading**

Magnetic box adhering to the metal casing of the machine

Centering of the **spindle, counter-operations, support of bits** by the same principle

Adapts to **all machines** : Lathes, milling machines, transfer machines, multi-spindle, machining centres, etc.

Introduction

Please comply with the regulations enforced in your country for the disposal of accumulators and electronic components. If you are not sure about the proper disposal, you can return the device to Wibemo SA.

The device is guaranteed for 2 years from the date of delivery (copy of the delivery note is proof). Opening the Mowidec-TT box without the authorization of WIBEMO SA will void the warranty. For all repairs, modifications or disposal, please contact your dealer or return the device to WIBEMO SA.

The MOWIDEC-TT device is powered by 2 rechargeable batteries of type AAA 1.2V, 800 mAh. The lifetime of the accumulators is about 10,000 charge / discharge cycles. WIBEMO SA replaces the accumulators. In case of incorrect handling or use of the device when opening the box, dropping, shaking the box or any mishandling contrary to the recommendations, the warranty is no longer valid.



Service instruction

Recommendations

Before the first use, plug in the power cable (9) on the computer / machine USB port or to the mains through the delivered transformer (8). The full load is usually reached after 2-3 hours of connection.

The percentage of the level of charge is indicated on the display screen of box A (100% at full load). When the charge level indicates "low", charging is needed immediately. It is possible to continue to use the device when it is connected to a power source using the proper cable.

The accuracy of measurement depends on the level of charge and it is not advisable to use the device if the level of charge is less than 25%.

It is advisable to switch off the appliance after use. To save the accumulators, the device switches itself off after a few minutes of inactivity.

Thanks to its magnetic base box, the device can be put in a visible place on the external casing of the machine or any metal sheet surface. Do not expose the device and accessories to liquid or corrosive products (chemical agents, oil, hydrocarbons, benzine, etc.). It is not advisable to attach the device inside of the machining areas of the machine. The box is not watertight and any contact with oil or water can seriously damage the electronic device.

Do not leave the device switched on with the detector connected for an excessive period of time. Unplug the appliance or the probe as soon as the measurement is finished. If used for a long time, the probe may overheat. This is normal but in case of extended use, the life of the probe may be significantly reduced.

Avoid any shock or contact with the measurement probe (detector) on. If it is damaged, its operation may be disrupted and errors of measurements are possible. Do not tighten or pull the connection cable (11) when the sensor (10) is connected so as not to damage the micro-connectors.

After each use, carefully clean the device with a soft and dry cloth to eliminate any traces of grease or oil, and put it away with its accessories in its protective transport case.

Measuring probes operate inductively.

Avoid allowing the device or probe to touch or get near to magnets or external magnetic sources so as not to damage it.

Measurement is possible only if the probe is between the detection fields of ferrous materials (steel, hard metal, etc.). The device does not work with (non-ferrous) materials like aluminium, brass, synthetic, etc. If in doubt, replace the measuring tool with a rectified cylinder in hard metal which will serve as a measurement standard.

Service instruction

Recommendations

The detection field of the probes are limited to the following maximum distance:

Mowi-Det-400	<1.0 mm max.
Mowi-Det-650	<2.0 mm max.
Mowi-Det-H	<1.0 mm max.
Mowi-Det-P	<1.0 mm max.

The measurement resolution of the probes is around 0.001 mm. The quality of the inductive signal of the probe may be influenced by the environment. The measurement remains indicative. When the material to measure is outside the detection field of the probe, the displayed value remains at the maximum of the capacity, 1.0 or 2.0 mm !

Service instruction

Mowidec-TT basic device

A Electronic unit



1
Playback screen

- 2 RESET — Reset button
- 3 mm/inch — Measurement unit : mm or Inch
- 4 UNIT — Measuring accuracy : 1.0 / 0.1 / 0.01 / 0.001
- 5 ON/OFF — ON / OFF



6 — Detector connection plug

7 — Supply plug electric 5V
(rechargeable on the mains or on the USB socket of the machine)



8 — Transformer
100-240V 50-60Hz / 5V

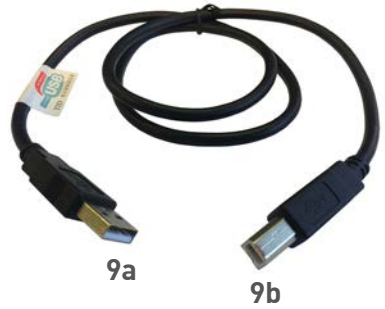

9a 9b



To be able to use your centring system, you need the following additional elements :



OPTIONS

a detector (Ø 4 or 6.5 mm)



10

one or more adaptation rings (depending on the type of machine)



12

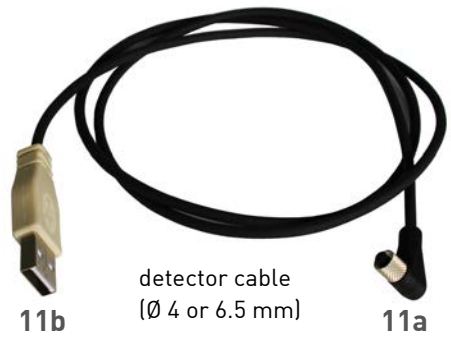

11b

detector cable (Ø 4 or 6.5 mm)

11a

Service instruction

Connections and basic settings

1. Connect the cable (9b) to the power supply plug of the unit (7). Connect the USB plug (9a) to a USB power source or the transformer (8) connected to the mains. Leave the appliance on charge during 2-3 hours to reach a 100% charge level. Once the batteries are charged, it is possible to use the device freely.

The device can also be used during the charging phase when it is connected to a power source.

2. Switch on the box (A) by pressing ON (5).
3. Select the measurement unit - mm / inch (3).
4. Select the UNIT display resolution (4).
5. Select the type of inductive detector used (10).
NB. The detector \varnothing 4.0 mm or square 5x5 Mowi-Det-H = Sensor 1
The detector \varnothing 6.5 mm or flat Mowi-Det-H = Sensor 2

To choose the type of sensor 1 or 2, press the Reset (2) and UNIT (4) keys together for 10 seconds and check the digital display of the unit (1) - see illustration.

Warning! No detector cable (11) may be connected during this operation.

If necessary, turn off the device, disconnect the detector cable (11) and start the operation again.

6. Connect the detector cable (11b) to the unit (6).
7. Gently adjust the desired detector (10) on the cable (11a)
8. Check the operation of the detector using a ferrous element. The display should indicate measurement variations when the ferrous element is closer or further away the detector.
9. Put the unit (A) on the external bodywork of the machine (magnetic base) to facilitate the reading of the digital display.
10. The product is now ready for use.



Sensor1 = detector \varnothing 4 mm or Mowi-det-H



Sensor 2 = detector \varnothing 6.5 mm

[ATTENTION : never connect the plug 11b to a computer or othe device. Never connect another USB socket to the Mowidec-TT. Risk of serious damage to the device or the computer].

Service instruction

Basic techniques for use



The measurement is done through an inductive detector on a **cylindrical part** (rectified hard metal cylinder, bit body, mill at the end, etc.) of \varnothing 0.05 mm min. Never make a measurement on the screw of a bit because the accuracy cannot be guaranteed.



The measurement accuracy is directly influenced by :

- the distance between the detector and the tool (the further away it is, the more the resolution of the measurement decreases)
- the tool diameter
- the shape of the tool (only usable with a cylindrical shape)
- the material of the tool (HSS or hard metal)

It is easier to make measurements when the environment of the work area is freed from devices and tools fitted on the machine.

1. Put an adequate ring (12) on the spindle / counter spindle nose or the turning barrel holder and secure it.
2. Insert the detector (10) on the ring (12) and fix it.
3. Connect the detector cable (11) and switch on the unit
4. Position the cylindrical part of the centring tool as close as possible to the detector by manually moving the mobile components (counter-spindle for example).
5. Adjust the height of the detector as near as possible to the surface of the measuring tool without being in contact. Leave a space of about 0.2 - 0.8mm. (beyond 1.0 mm distance, the detector is no longer active with accuracy). Lock the position of the detector by means of the screw.
6. Rotate the ring with the detector around the tool to make sure that there is no contact with the measuring tool. Also make sure the rotation of the ring does not collide with the tools and devices arranged in the work area. In some cases where the space is reduced, the use of the Mowi-Kit-Addet-H support may offer an easier approach to make measurements (cf. next chapter).
7. The device is now in place to make measurements.

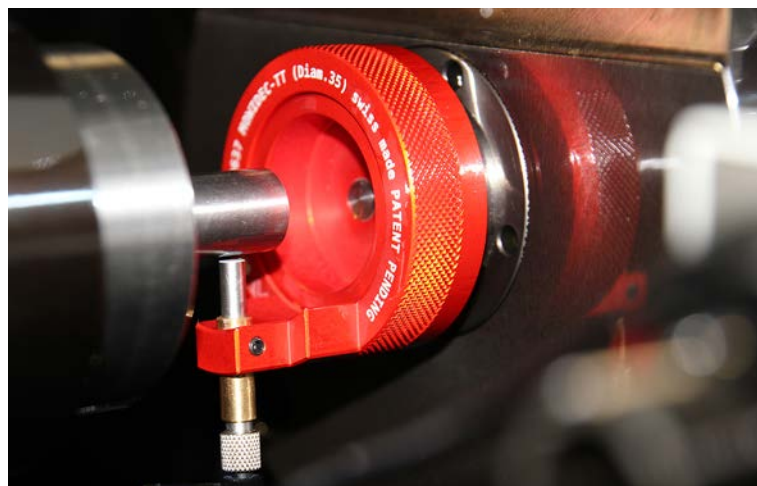

Service instruction

Measurement technique

This centring device is not a literal measurement system but rather a means of comparison between different given points.

The device cannot be used to make a real measurement because the interpretation of values given by the inductive detector are variable depending on the proximity of the objects to centre. We seek, by this principle, only to define a rotation centre. We must therefore define a revolution centre only by the comparison of position of 3 equidistant points. This being the case, there is no need to calibrate the device because a possible error of measurement will be repetitive and never influences the search of the revolution centre.

To obtain an accurate and rapid result during the centring operation, we advise you to proceed in the following manner :

Position 1



1. Position the detector in "12 o'clock" position (Position 1)
2. Press RESET (2) to reset the display to zero
3. This position is now the basic reference to start the measurement
4. Rotate the ring through 180° manually by taking care not to pull or force the cable
5. Position the detector in opposite "6 o'clock" position (Position 2)
6. The value now indicated on the screen represents the measured gap between the 2 points on a vertical plane.

Position 2



7. Make a correction of the position by moving the numeric axis of **half of the displayed value** (attention to respect the +/-) 
8. Once the correction is made, press RESET (2) to define this position as a new measurement reference.
9. Rotate through 180° again to return to the starting point "12 o'clock" Position 1)
10. The display then indicates a new value under the previous one
11. Repeat the operation according to points 7-8-9 until the value approaches zero

Position 3
left or right



12. When the positioning of the 2 "12 o'clock" and "6 o'clock" points will be equidistant or close to zero, the middle will have been defined in the vertical plane
13. Press RESET (2) and rotation through 90° to the left or the right of the vertical axis (Position 3). The displayed value will now show the off-centre value on a horizontal plane
14. Make a correction corresponding **with the total value** of the displayed measurement (observe the +/-) to approach the zero
15. When the 3 points display an identical value, the exact centre of rotation of the tool is found.
16. This position may be introduced as reference 0 and/or the values introduced in the offsets of the CN

Service instruction

Centring of the counter-spindle / counter-operations

The way to proceed to centre the pins of counter-operations is identical. The adequate ring must be adjusted on the nose of the counter-spindle. It is also possible to check the alignment of the counter-spindle in respect to the barrel.

Centring and alignment of the headstock + counter-spindle

The alignment barrel allows you to align: the headstock, barrel and counter-spindle of your machine.

Before anything else make sure you have the alignment barrel and the corresponding counter-spindle ring for your machine. (example for DECO-13: alignment barrel 1353 and the red ring 150637).

Fit the ring on the nose of the headstock with the detector measuring the cylindrical part **1** of the alignment barrel. You can centre and align the headstock with the barrel holder.

Then attach the ring on the nose of the counter-spindle and centre the counter-spindle with the barrel by measuring on the cylindrical part **2**.



Centring of pins at the end and counter-operations

To facilitate the centring when you do not have tool or rectified barrel, we propose the use of a measurement standard.

Different high precision supports are available with a clamp base ER/ESX and a rectified cylinder. This support is mounted in the place of the clamp and the bit and allows you to centre each position of the support individually.

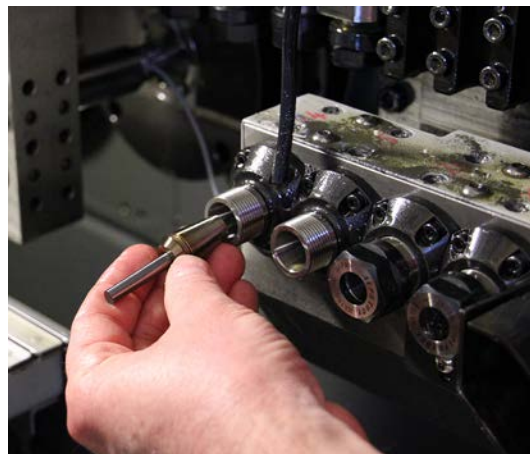

Service instruction

Specific application

To provide a solution to each particular case, we propose a various detectors which can be controlled individually.

If you want to create your own support in the framework of a custom application, we put all the elements at your disposal separately.

For example, you can yourself create by means of measurement via the Mowi-Det-P flat probe or use a bushing blank.

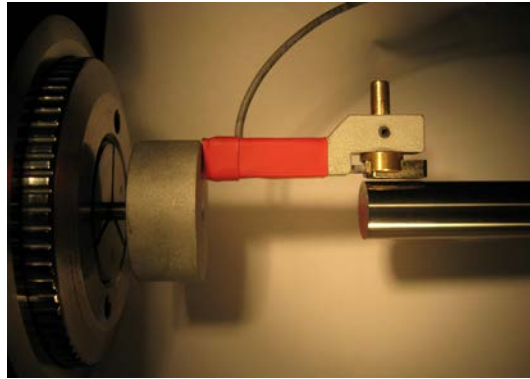

Service instruction

Centring of spinles with a bushing of adapter material ring

If your machine does not allow you to place a bushing on the nose of the barrel holder or the nose of your counter-spindle, you can use an adapter material bushing which is fixed directly on your material.

Indeed, the adapter material bushing suitable for all uses or it is impossible to fit a standard bushing on your machine.

Simply drill the material bushing to the diameter of your bar.



As an alternative, you can also turn the bar to the diameter of the bushing.

Adjust the material bushing directly on the material protruding from the barrel and secure with the locking screw.



Then lay the probe holder bushing on the material bushing and secure it with the locking screw.

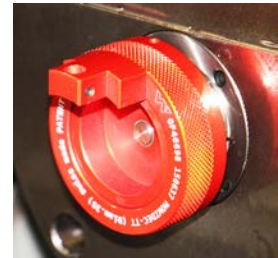

Turn the detector in the hole of the standard bushing and connect the detector to the unit.



Your device is ready for centring.

The adaptation is intended for machines using :

- a fixed barrel
- working as a clamp
- barrel turning on machines of type Citizen, Star, Tsugami, Hanwha, Traub, Gildemeister, etc...

The material bushings available are :

150709	with bushing 150675	detector Ø 4.00
150711	with bushing 150637	detector Ø 4.00
150761		detector Ø 6.50
150911	with bushing 150870	detector Ø 4.00

Service instruction

Centring of pins with a reduced space

When the position of the spindles and / or the tools to centre are too close together, the use of the standard detector is not always possible for lack of space.

To overcome this problem, we have specially developed a detector with a sensor located on the side and allowing a side measurement between the tools. This Mowi-det-H detector has a measuring accuracy of 0.001 mm. It can be introduced between spindles without having to remove or move the bits during the centring.

To be able to measure different lengths of bits, the detector can be mounted on supports of length 20 or 40 mm. These supports are supplied in the Mowi-kit-addet-H adequate assembly kit.

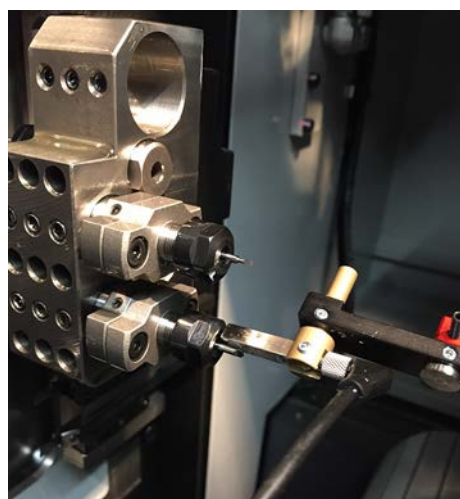
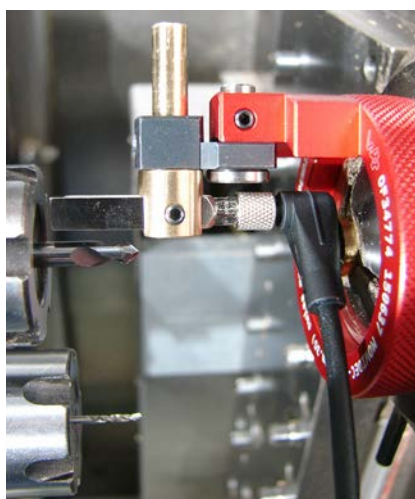

This adapter kit can be used with all the bushings with a hole for the detector \varnothing 4.5 mm or 6.5 mm. The Mowi-Connect-400 connector used for the \varnothing 4.5 detector is also compatible with the square detector.

When fitting on the support, be sure not to damage the square detector. Insert by sliding from the outside toward the inside.

This kit is also fitted on a material bushing. You can thus use it on all machines.

Mowidec-TT

this installation requires 3 elements :

- 1 bushing
- 1 Mowi-kit-addet-H
- Mowi-det-H square probe

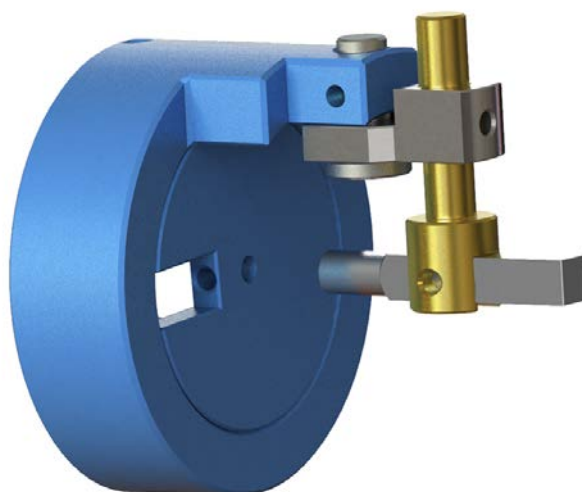

Service instruction

For centring of the tool-holder in reduced spacing and tool holders placed on the horn of your machine, you have the possibility to use a specific centring support.

This horn centring support is made up of 3 components :

- a cylindrical support for interchangeable head n° 13 (Mowi-Cyl Ø of the body)
- an interchangeable mobile head for probe n° 14 (Mowi-T)
- a flat probe n° 15 (Mowi-det-P)

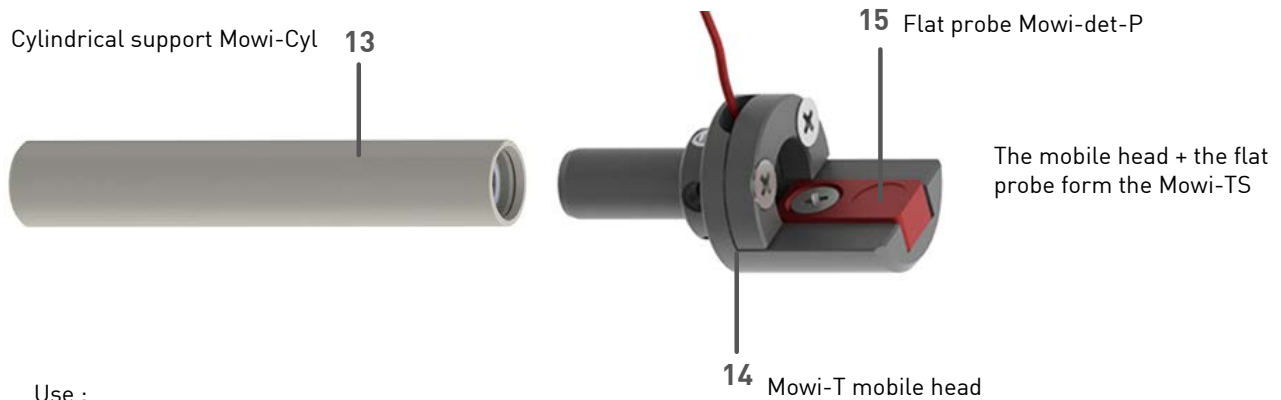





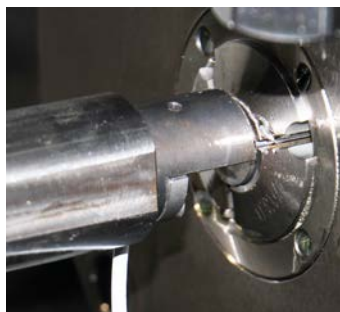









Use :



















- 1 For optimal use it is necessary to have a section of the matter of $\varnothing 3.00$ mm protruding from the barrel (see photo to the right) or use a rectified cylinder MD $\varnothing 3.00$ mm
- 2 Place the Mowi-Cyl no. 13 body in the tool holder / horn housing and then insert the Mowi-t no. 14 mobile head in the support. Then install the Mowi-det-P no. 15 probe on the mobile head (see illustration above)
- 3 Connect the cable of the Mowi-det-P no.15 probe to the connection plug of the unit no. 6
- 4 Repeat the instructions described in the chapter "Basic techniques of use" knowing that the mobile head will serve as a bushing (see photo below).





















Service instruction

Item No	Description	Sensor	Type
Mowi-boîtier V2.0	 Read out unit with battery power supply with USB cable		
Mowi-det-400	 Probe Ø 4 mm incl. brass protection		Mowi-connect-400 Bagues accueillant le détecteur Ø 4
Mowi-connect-400	 Connection cable for Sensor Ø 4 mm + square sensor		
Mowi-det-650	 Probe Ø 6.5 mm incl. brass protection		Mowi-connect-650 Bagues accueillant le détecteur Ø 6.5
Mowi-connect-650	 Connection cable fo Sensor Ø 6.5 mm		
Mowi-det-H	 Square Sensor 5.00 x 5.00 mm		Mowi-kit-addet-H Mowi-connect-400 Bague d'adaptation matière
Mowi-Det-P	 Flat probe (16 mm x 8 mm x 4.8 mm) with reduced dimension incl. integrated cable		
Mowi-kit-addet-H	 Adaptation kit for sensor Mowi-det-H including short and long support. To be used on rings Ø 4 mm / 6.50 mm		Utilisable sur les bagues avec un trou pour détecteur Ø 4 / 6.50 mm
Mowi-valise	 Valise vide pour dispositif Mowidec		
Mowi-trans-EU	 Power supply cable 100-240V with transformer 5V / 50 - 60 Hz		
Mowi-trans-USA	 Power supply cable 100-240V with transformer 5V / 50 - 60 Hz USA		
150218	 Adapter ring Ø 57.00 mm	Mowi-det-650	
150567	 Adapter ring Ø 27.00 mm	Mowi-det-400	
150637	 Adapter ring Ø 35.00 mm	Mowi-det-400	
150638	 Adapter ring Ø 45.00 mm	Mowi-det-400	













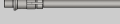

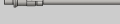

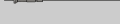







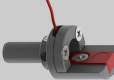

Service instruction

Item No	Description	Sensor
150641	 Adapter ring Ø 48.00 mm	Mowi-det-650
150642	 Adapter ring Ø 60.00 mm	Mowi-det-650
150675	 Adapter ring Ø 25.00 mm	Mowi-det-400
150678	 Adapter ring Ø 50.00 mm	Mowi-det-650
150686	 Adapter ring Ø 42.20 mm	Mowi-det-400
150687	 Adapter ring Ø 29.00 mm	Mow-det-400
150707	 Adapter ring Ø 45.90 mm	Mowi-det-650
150708	 Adapter ring Ø 34.85 mm	Mowi-det-400
150709	 Bar cover head D25 (Blank) bore Ø 0.80 mm	
150709-xxx	 Bar cover head D25 (Blank) bore Ø	
150711	 Bar cover head D35 (Blank) bore Ø 1.50 mm	
150711-xxx	 Bar cover head (Blank) bore Ø	
150717	 Adapter ring Ø 48.95 mm	Mowi-det-650
150721	 Adapter ring Ø 54.00 mm	Mowi-det-650
150722	 Adapter ring Ø 51.85 mm	Mowi-det-650
150723	 Adapter ring Ø 67.00 mm	Mowi-det-650
150724	 Adapter ring Ø 61.00 mm	Mowi-det-650
150725	 Adapter ring Ø 32.00 mm	Mowi-det-400
150726	 Adapter ring Ø 36.00 mm	Mowi-det-400

Service instruction

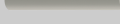
Item No	Description	Sensor
150735	 Adapter ring Ø 50.25 mm	Mowi-det-650
150736	 Adapter ring Ø 64.25 mm	Mowi-det-650
150761	 Bar cover head D64 (Blank) bore Ø 5.00 mm	Mowi-det-650
150761-xx	 Bar cover head (Blank) bore Ø	Mowi-det-650
150870	 Adapter ring Ø 23.00 mm	Mowi-det-400-nano
Mowidec-kit-Nano	Complete kit for Swiss Nano content : 150870 + 150911 + Mowi-det-400	
150911	 Bar cover head bore Ø 0.80 mm for ring 150870 Ø 23.00 mm	
150911-xxx	 Adapter ring 150911 with bore on request	
150963	 Adapter ring Ø 33.00 mm	Mowi-det-400
151142	 Adapter ring Ø 43.00 mm	Mowi-det-400
151143	 Adapter ring Ø 49.60 mm	Mowi-det-650
151144	 Adapter ring Ø 64.60 mm	Mowi-det-650
151184	 Adapter ring Ø 38.00 mm	Mowi-det-400
151202	 Adapter ring Ø 58.00 mm	Mowi-det-650
151203	 Adapter ring Ø 65.00 mm	Mowi-det-650
151204	 Adapter ring Ø 44.00 mm	Mowi-det-650
151205	 Adapter ring Ø 76.00 mm	Mowi-det-650
151214	 Adapter ring Ø 66.00 mm	Mowi-det-650
151215	 Adapter ring Ø 37.00 mm	Mowi-det-400
151217	 Adapter ring Ø 75.00 mm	Mowi-det-650

Service instruction

Item No	Description	Sensor
151219	 Adapter ring Ø 56.00 mm	Mowi-det-650
Mowi-1351-P-CP	 Alignment guide bush 1351	
Mowi-1352-P-CP	 Alignment guide bush 1352	
Mowi-1353-P-CP	 Alignment guide bush 1353	
Mowi-1603-P-CP	 Alignment guide bush 1603	
Mowi-223T-P-CP	 Alignment guide bush 223T	
Mowi-229T-P-CP	 Alignment guide bush 229T	
Mowi-39001T-P-CP	 Alignment guide bush 39001T	
Mowi-853-P-CP	 Alignment guide bush 853	
Mowi-605-P-CP	 Alignment guide bush 605	
Master ER8	 Master ER8	
Master ER11	 Master ER11	
Master ER16	 Master ER16	
Master ER20	 Master ER20	
Master ER25	 Master ER25	
Master ER32	 Master ER32	
Mowi-T	Exchangeable centering head (without probe)	
Mowi-TS	 Exchangeable centering head complete, incl. Flat probe Mowi-det-P	
Mowi-Cyl08	 Cylindrical holder Ø 8.0 for exchangeable head (without head)	
Mowi-Cyl12	 Cylindrical holder Ø 12.0 with flat for exchangeable head (without head)	
Mowi-Cyl1587	 Cylindrical holder Ø 15.87 (5/8") with flat for exchangeable head (without head)	
Mowi-Cyl16	 Cylindrical holder Ø 16.0 with flat for exchangeable head (without head)	
Mowi-Cyl1905	 Cylindrical holder Ø 19.05 (3/4") with flat for exchangeable head (without head)	
Mowi-Cyl20	 Cylindrical holder Ø 20.0 with flat for exchangeable head (without head)	
Mowi-Cyl22	 Cylindrical holder Ø 22.0 with flat for exchangeable head (without head)	
Mowi-Cyl25	 Cylindrical holder Ø 25.0 with flat for exchangeable head (without head)	
Mowi-Cyl254	 Cylindrical holder Ø 25.40 (1") with flat for exchangeable head (without head)	
Mowi-Cyl28	 Cylindrical holder Ø 28.0 with flat for exchangeable head (without head)	
Mowi-Cyl32	 Cylindrical holder Ø 32.0 with flat for exchangeable head (without head)	
Mowi-Cyl35	 Cylindrical holder Ø 35.4 with flat for exchangeable head (without head)	